

New Updated Design

# E-Z Sleeper

**VERSATILE CONVENIENT UNIFORM ECONOMICAL**



- **Supports up to 450 lbs.**
- **Evenly distributes weight**
- **Environmentally Friendly – can be recycled**
- **Closed cell polystyrene base held solidly through design – not glue**



**UV Resistant  
Polypropylene  
Years of worry  
free performance**



**6" height is perfect  
for elimination of  
old wood blocks  
No pipe adjustments**



**R & R Friendly**

- **Integrated channel uses standard strut clamps**
- **Ideal for Electrical and HVAC contractors**
- **Built-in tubes provide a variety of extension possibilities using threaded rod**
- **Base is removable for easy access installing rod**



**Temporary installation  
straps available  
Assembly of long runs  
becomes a one man job**



**Distributed by:**

# SPECIFICATIONS

## Product Description

E-Z Sleeper is designed to replace the current practice by skilled trades people of building wooden blocks for support of vital mechanical infrastructure on flat roofs including;

- gas pipe
- electrical conduit
- refrigeration piping

The roof block is an assembled product comprised of two major components including the support shell which is an one piece, UV resistant, thermoplastic injection molded Polypropylene Impact Copolymer and the Type 3, 20 psi extruded polystyrene non-marring base. The support shell is designed with an interior web maximizing support strength while substantially reducing the overall weight. Interior cavities allow for expansion and contraction under extreme temperature conditions over its lifetime. The lower portion of the one-piece support shell incorporates a 3/4" high wall which reduces UV exposure to the extruded polystyrene base.

## Typical Physical Properties of Non-Marring Base (OC Canada – Type III, CAN/ULC- S701 - 97)

Thermal Resistance (Ft <sup>2</sup> hr °F/B T U) (m <sup>2</sup> °C /W )	Compressive Strength, min (psi) (kpa)	Water Absorption, max. (% by volume)	Water Vapour Permeance, max. (perms) (ng/Pa.s.m <sup>2</sup> )	Water Capillarity	Water Affinity	Flexural Strength, typical (psi) (kpa)	Max. Operating Temperature (°F) (°C)
5.0	20	0.70	0.85	None	Hydrophobic	44	165
0.87	140		49			300	74

## Compression Testing - Refer to ASTM - D1708-02a Standard Test Method for Tensile Properties of Plastics

**Base:** 13 3/4" square 1/4" square steel plate on Pedestal post

**Crosshead/Arm Probe:** 5 1/2" diameter x 5/8" thick machined disk on post - roof block located on centerlines between the machine frame

**Machine Mode:** general compression

**Crosshead travel speed:** 0.10" per minute

**Maximum load setting:** 1,200 pounds - no product failure

**Maximum deflection:** 0.50 inches

**Temperature/Humidity:** 73°F/50%

Output report settings: pounds of compressive load vs inches deflection (Note: output can be displayed in many other settings such as stress vs strain)

The block sustained compression with **no mechanical fracture** up to the maximum limits of the test (1200 pounds). The extruded polystyrene base absorbed much of the load and was the primary (maybe only) cause for deflection. The mechanical compression was spread through the 5 1/2" disk that contacted the mounting area in the centre of the block (14.84 in<sup>2</sup> of contact surface).

## Pull Test - Refer to ASTM - D2990-01 Standard Test Methods for Tensile, Compressive, Flexural Creep and Rupture of Plastics

The test revealed the best-case scenario for installation of the 2-hole galvanized pipe straps, mounted to the roof block using fasteners available locally. The test data suggests that the most coarse thread and largest diameter head type screws should be used for ideal installation. The installer may use the type of screw best for their specific application, *although a coarse screw with a large head diameter will maximize retention.*

Screw Type	Force	Test #1	Test #2	Test #1	Test #2	Test #1	Test #2	Average	Geomean
		2.5" horseshoe clamp	2.0" horseshoe clamp	2.0" horseshoe clamp	2.0" horseshoe clamp	1.5" horseshoe clamp	1.5" horseshoe clamp		
Sheet Metal #14-10	Extension @ break	319.27	279.47	242.46	308.18	460.97	282.66	<b>315.50</b>	<b>308.90</b>
		0.656	0.600	0.441	0.467	0.790	0.421	<b>0.563</b>	<b>0.55</b>

## Special Notes:

- ① Roller extension kits available for pipe expansion/contraction
- ② Strut extension kits available for adjustable height conduit installation
- ③ Custom support solutions available (contact manufacturer)

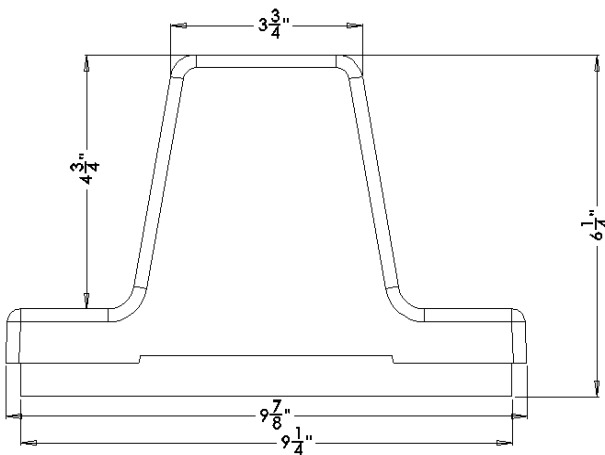

End View

The top view shows the integrated channel that uses standard strut accessories. It also shows the cylinder inserts for the use of threaded rod that allows a wide variety of extension capabilities.

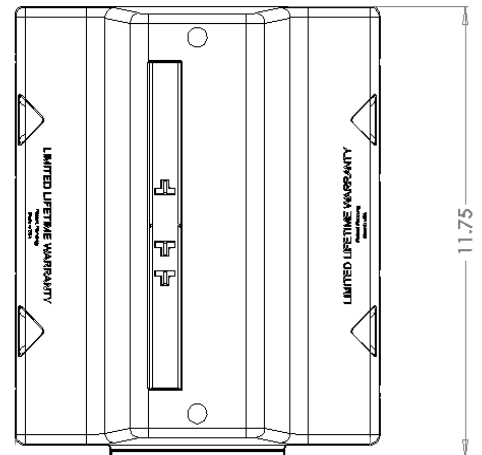

Top View